

Feature: Units with vertically moving and sliding arms. Machine the arm section to use for work piece measurements.

### Hinge Units for Fixtures-Vertical



\* The fulcrum pin is sold separately **P.795-** **RoHS**

### JHTS Relief

(Depth 0.5-2, Width W-20)

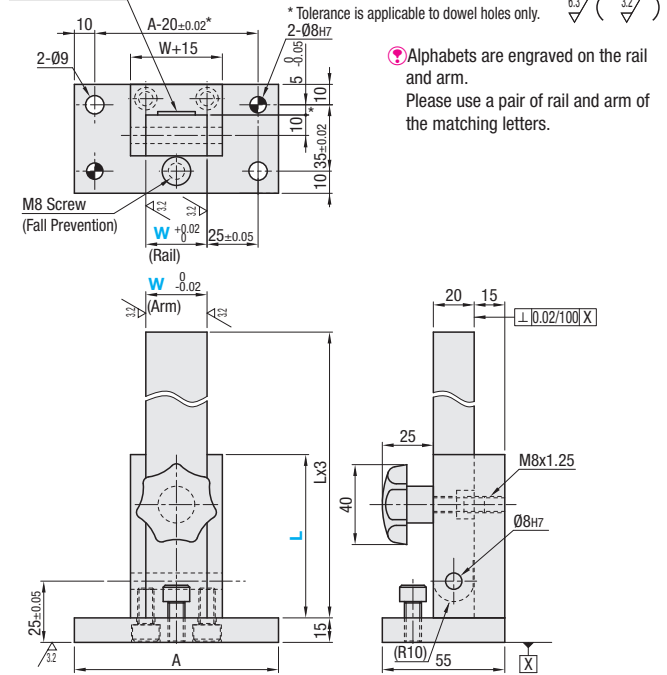

Alphabets are engraved on the rail and arm.  
Please use a pair of rail and arm of the matching letters.

Material: 1045 Carbon Steel

Part Number	L	A	Unit Price
<b>JHTS</b>	30	60	100
	50	80	120

Ordering Example	Part Number	L	B
	JHS20	60	
	JSS20	40	
	JHSP100		75
	JHTS30	60	

Days to Ship [Configure Online](#)

Price [Configure Online](#)

Alterations	Part Number	L	(STC, NB, LC)
Knob Bolt Set for Tightening and Fixing Material: 1045 Carbon Steel Surface Treatment: Electroless Nickel Plating	JHS20	60	NB
	JSS20	60	LC20
	JHTS50	80	LC10

Alterations	Code	Spec.	Price Adder
Additional Surface Treatment (Black Oxide)	STC	Adds black oxide surface treatment.	
Knob Bolt Set for Tightening and Fixing Material: 1045 Carbon Steel Surface Treatment: Electroless Nickel Plating L Dimension Cut LC	NB	Instead of L pin hole, a knob-bolt is installed. A dedicated knob-bolt (Retained) is included. *Applicable to W20, 30, 50 of JHS. <ul style="list-style-type: none"> <li>Knob-bolt has retained structure.</li> <li>The Knob Bolt's threaded section retracts into the counterbore when the arm is lowered not damage the rail.</li> </ul>	
L Dimension Cut LC	LC	Cuts L dimension of the arm. [Ordering Code] LC20 (10mm Increment) *10≤LC≤Lx2	
Position of Bottom Face Mounting Hole	SYM	Positions the dowel hole and mounting hole symmetrically. *Applicable to JHTS only.	

